

POLARIZING KEY
 TYCO PART NUMBER: 1-1437023-2
 T&B PART NUMBER (REF): 609-0000
 PURCHASE SEPARATELY

- 20 POSITION CONNECTOR ASSEMBLY SHOWN.
- MOLDED PARTS: THERMOPLASTIC, UL94V-0 RATED, COLOR BLUE. CONTACTS: BERYLLIUM COPPER.
- CONTACTS: 0.00076[.000030] MIN GOLD ON MATING AREA, 0.00254-0.00508[.000100-.000200] TIN ON TERMINATION END, ALL OVER 0.00127[.000050] MIN NICKEL ON ENTIRE CONTACT.
- CONTACTS: 0.00127[.000050] MIN GOLD ON MATING AREA, 0.00254-0.00508[.000100-.000200] TIN ON TERMINATION END, ALL OVER 0.00127[.000050] MIN NICKEL ON ENTIRE CONTACT.
- POLARIZER FEATURE DOES NOT EXIST ON POSITION #1 END FOR 14 POSITION AND SMALLER ASSEMBLIES.
- POLARIZER FEATURE DOES NOT EXIST ON THIS END FOR 6 POSITION ASSEMBLY.
- FOR TERMINATION OF 28 OR 30 AWG STRANDED PVC INSULATED FLAT RIBBON CABLE.
- STRAIN RELIEF PACKAGED SEPARATELY AND SHIPPED WITH ASSEMBLY.
- DATE CODE STAMPED ON THIS SIDE OF CONNECTOR. 6 POSITION CONNECTORS EXCLUDED.
- ALTERNATE COVER END APPLIES TO INDICATED NUMBERS.

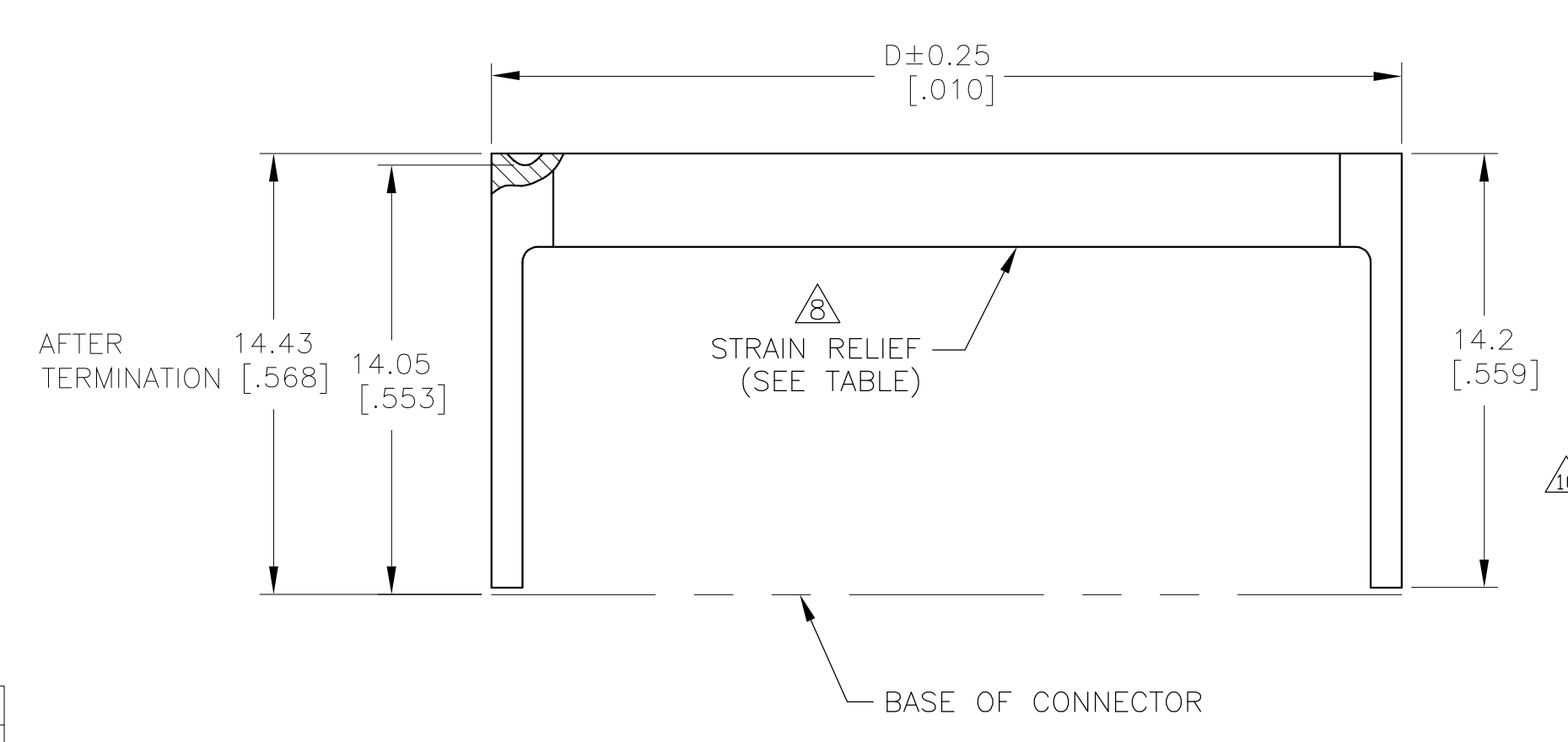
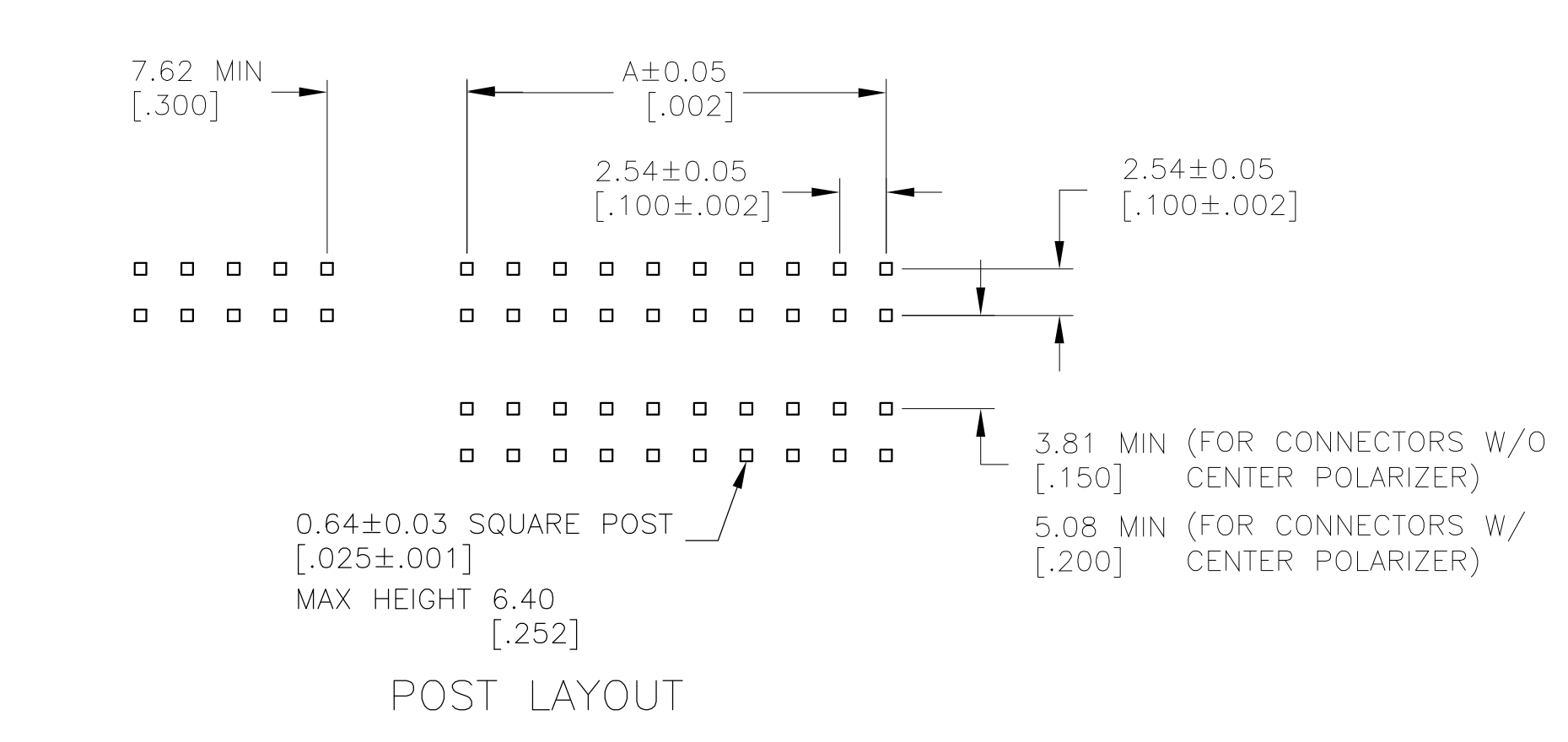
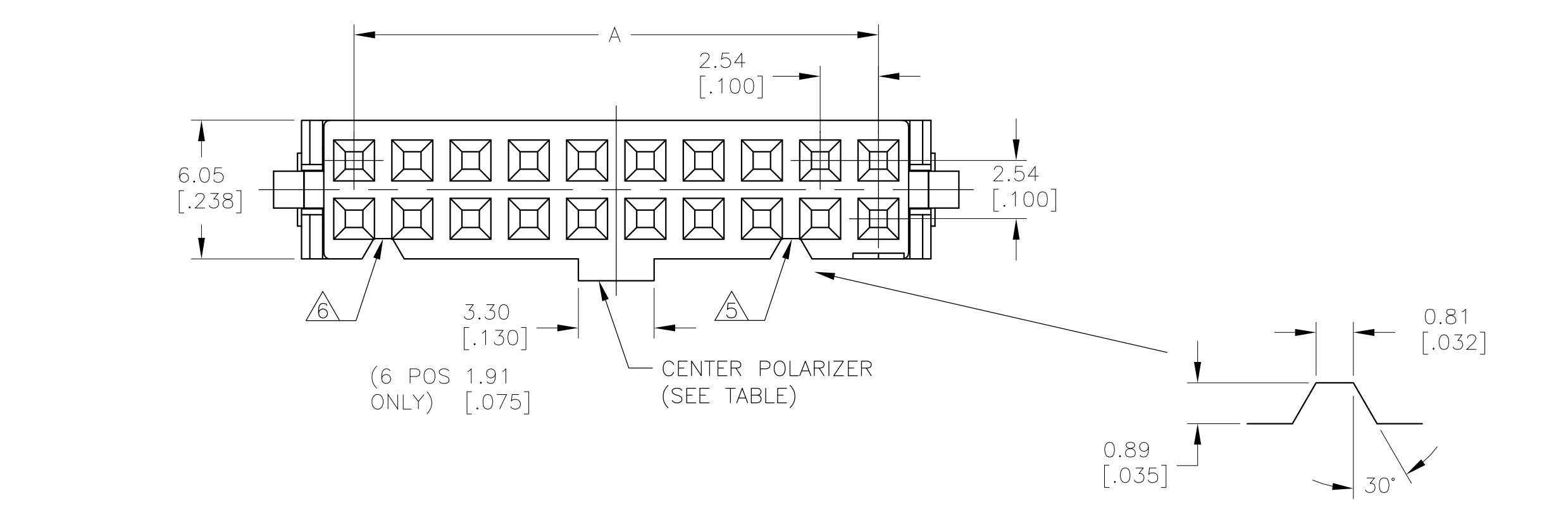

OBsolete	YES	YES	3	85.65[3.372]	85.75[3.376]	80.01[3.150]	78.74[3.100]	64	609-6441LF	4-1658526-5
OBsolete	NO	YES	3	-	85.75[3.376]	80.01[3.150]	78.74[3.100]	64	609-6430LF	4-1658526-4
	YES	YES	5	67.87[2.672]	67.97[2.676]	62.23[2.450]	60.96[2.400]	50	609-5041LF	2-1658526-4
	NO	YES	3	-	67.97[2.676]	62.23[2.450]	60.96[2.400]	50	609-5030LF	2-1658526-3
	YES	NO	3	67.87[2.672]	67.97[2.676]	62.23[2.450]	60.96[2.400]	50	609-5001MLF	2-1658526-2
	NO	NO	3	-	67.97[2.676]	62.23[2.450]	60.96[2.400]	50	609-5000MLF	4-1658526-3
	YES	YES	3	55.17[2.172]	55.27[2.176]	49.53[1.950]	48.26[1.900]	40	609-4041LF	2-1658526-1
	NO	YES	3	-	55.27[2.176]	49.53[1.950]	48.26[1.900]	40	609-4030LF	2-1658526-0
OBsolete	YES	NO	3	55.17[2.172]	55.27[2.176]	49.53[1.950]	48.26[1.900]	40	609-4001MLF	4-1658526-2
OBsolete	NO	NO	3	-	55.27[2.176]	49.53[1.950]	48.26[1.900]	40	609-4000MLF	4-1658526-1
	YES	YES	5	50.09[1.972]	50.19[1.976]	44.45[1.750]	43.18[1.700]	36	609-3641LF	4-1658526-0
	NO	YES	3	-	50.19[1.976]	44.45[1.750]	43.18[1.700]	36	609-3630LF	3-1658526-8
	YES	YES	3	47.55[1.872]	47.65[1.876]	41.91[1.650]	40.64[1.600]	34	609-3441LF	1-1658526-9
	NO	YES	3	-	47.65[1.876]	41.91[1.650]	40.64[1.600]	34	609-3430LF	1-1658526-8
OBsolete	YES	NO	3	47.55[1.872]	47.65[1.876]	41.91[1.650]	40.64[1.600]	34	609-3401MLF	3-1658526-7
OBsolete	NO	NO	3	-	47.65[1.876]	41.91[1.650]	40.64[1.600]	34	609-3400MLF	1-1658526-7
	YES	YES	3	37.39[1.472]	37.49[1.476]	31.75[1.250]	30.48[1.200]	26	609-2641LF	1-1658526-6
	NO	YES	3	-	37.49[1.476]	31.75[1.250]	30.48[1.200]	26	609-2630LF	1-1658526-5
OBsolete	YES	NO	3	37.39[1.472]	37.49[1.476]	31.75[1.250]	30.48[1.200]	26	609-2601MLF	3-1658526-6
OBsolete	NO	NO	3	-	37.49[1.476]	31.75[1.250]	30.48[1.200]	26	609-2600MLF	3-1658526-5
OBsolete	YES	YES	3	34.85[1.372]	34.95[1.376]	29.21[1.150]	27.94[1.100]	24	609-2441LF	3-1658526-4
OBsolete	NO	YES	3	-	34.95[1.376]	29.21[1.150]	27.94[1.100]	24	609-2430LF	1-1658526-4
OBsolete	NO	NO	3	-	34.95[1.376]	29.21[1.150]	27.94[1.100]	24	609-2400MLF	3-1658526-3
	YES	YES	5	29.77[1.172]	29.87[1.176]	24.13[.950]	22.86[.900]	20	609-2041LF	1-1658526-3
	NO	YES	3	-	29.87[1.176]	24.13[.950]	22.86[.900]	20	609-2030LF	1-1658526-2
OBsolete	YES	NO	3	29.77[1.172]	29.87[1.176]	24.13[.950]	22.86[.900]	20	609-2001MLF	3-1658526-2
OBsolete	NO	NO	3	-	29.87[1.176]	24.13[.950]	22.86[.900]	20	609-2000MLF	3-1658526-0
	NO	NO	4	-	29.87[1.176]	24.13[.950]	22.86[.900]	20	609-2000MP005LF	3-1658526-1
	YES	YES	5	24.69[.972]	24.79[.976]	19.05[.750]	17.78[.700]	16	609-1641LF	1-1658526-1
	NO	YES	3	-	24.79[.976]	19.05[.750]	17.78[.700]	16	609-1630LF	2-1658526-9
	YES	NO	3	24.69[.972]	24.79[.976]	19.05[.750]	17.78[.700]	16	609-1601MLF	1-1658526-0
OBsolete	NO	NO	3	-	24.79[.976]	19.05[.750]	17.78[.700]	16	609-1600MLF	2-1658526-8
	YES	YES	3	22.15[.872]	22.25[.876]	16.51[.650]	15.24[.600]	14	609-1441LF	1658526-9
	NO	YES	3	-	22.25[.876]	16.51[.650]	15.24[.600]	14	609-1430LF	1658526-8
OBsolete	YES	NO	3	22.15[.872]	22.25[.876]	16.51[.650]	15.24[.600]	14	609-1401MLF	1658526-7
OBsolete	NO	NO	3	-	22.25[.876]	16.51[.650]	15.24[.600]	14	609-1400MLF	1658526-6
	YES	YES	5	17.07[.672]	17.17[.676]	11.43[.450]	10.16[.400]	10	609-1041LF	1658526-5
	NO	YES	3	-	17.17[.676]	11.43[.450]	10.16[.400]	10	609-1030LF	1658526-4
OBsolete	YES	NO	3	17.07[.672]	17.17[.676]	11.43[.450]	10.16[.400]	10	609-1001MLF	2-1658526-7
OBsolete	NO	NO	3	-	17.17[.676]	11.43[.450]	10.16[.400]	10	609-1000MLF	1658526-3
	YES	YES	3	11.99[.472]	12.09[.476]	6.35[.250]	5.08[.200]	6	609-0641LF	1658526-2
	NO	YES	3	-	12.09[.476]	6.35[.250]	5.08[.200]	6	609-0630LF	1658526-1
OBsolete	YES	NO	3	11.99[.472]	12.09[.476]	6.35[.250]	5.08[.200]	6	609-0601MLF	2-1658526-6
OBsolete	NO	NO	3	-	12.09[.476]	6.35[.250]	5.08[.200]	6	609-0600MLF	2-1658526-5

ELECTRICAL PROPERTIES	
CURRENT RATING	1 AMP
INSULATION RESISTANCE	>1 x 10 ⁹ OHMS @ 500 VDC
DWV	>500 VRMS AT SEA LEVEL
ENVIRONMENTAL PROPERTIES	
TEMPERATURE RATING	-55°C TO 125°C

THIS DRAWING IS A CONTROLLED DOCUMENT.

APPROVED: J. GERACE, 30SEP03
 CHECKED: C. RHOHE, 30SEP03
 DRAWN: M. WALMSLEY, 30SEP03

TOLERANCES UNLESS OTHERWISE SPECIFIED:
 DIMENSIONS: mm(INCHES)
 0 PLC ± .01
 1 PLC ± .015
 2 PLC ± .02
 3 PLC ± .03
 4 PLC ± 0.13(.005)
 ANGLES ± .4°

MATERIAL: FINISH: SEE TABLE

APPLICATOR SPEC: WEIGHT: -

DATE: 10/07/09
 DRAWING NO: 1658526
 CUSTOMER DRAWING

Tyco Electronics Corporation
 Harrisburg, PA 17105-3608

CONNECTOR ASSEMBLY, FEMALE SOCKET TRANSITION

SIZE: A1
 CASE CODE: 00779
 DRAWING NO: 1658526
 RESTRICTED TO: -

SCALE: 10:1
 SHEET: 1 OF 1
 REV: D2